

Quadwheel® Installation & Operation Guide

Carlton 2300, 2400-4, 2500, 2700-4, SP4012 & SP5014



If you have any questions or concerns, please call 1-800-473-3683



BEFORE YOU BEGIN

Read these instructions completely and carefully.

- **Note to installer** – Be sure to leave these instructions for the consumer's use.
- **Note to consumer** – Keep these instructions with your Owner's Manual for future reference.
- **Skill level** – Installation of the wheel requires intermediate mechanical skills. Proper installation is the responsibility of the installer. Product failure due to improper installation is not covered under any warranty.
- **Helpful tips** – When installing a new v-belt it is recommended to check belt tension after 1 hour, 5 hours, 10 hours and 25 hours of machine operation as the belt will stretch.

IMPORTANT - Before you continue, please check the packing list to make sure it matches the contents of the boxes.



Disconnect Power

to machine to prevent any machine components from moving before proceeding. Failure to do so could result in death or serious injury.

FOR YOUR SAFETY read and observe all **CAUTIONS** and **WARNINGS** shown throughout these instructions. While performing the installations that are described in this booklet, gloves & safety glasses or goggles should be worn at all times.

Installation Preparation

TOOLS SUPPLIED:

½" Drive, ½" 6pt Impact Allen Wrench Socket

TOOLS YOU WILL NEED:

5/8" Socket Wrench

½" Drive Torque Wrench

Green-Seize™

TORQUE SETTINGS:

900 Series® Nut: 35ft. lbs. (47Nm)

LoPro® Bolt (lubricated with Green-Seize™): 180ft. lbs.

LoPro® Bolt (dry): 240ft. lbs.

MANUFACTURER'S PARTS LIST:

<i>Part Number</i>	<i>Description</i>
926-WS2	900 Series® Wearsharp® 2-sided Tooth, for wheels 22" & smaller, Used with Greenwheel® & Quadwheel®
GW-BLOCK	Mounting Block for Greenwheel® & Quadwheel®
GW-HOLDER	Tooth Holder Greenwheel® & Quadwheel®
LP-300	3" LoPro® Bolt
ALLENWRENCH-SOCKET	½" Drive, ½" 6pt Impact Allen Wrench Socket

Green Manufacturing, Inc.
9650 Packard Rd
Morenci, MI 49256
Phone 800.473.3683 • Fax 517.458.1550



Table of Contents

Disassembly Instructions	4
Quadwheel [®] Assembly Instructions	8
Assembling the Quadwheel [®] to Machine	9
Quadwheel [®] Drive Assembly – Expanded View	12
Taper-Lock [®] Bushing Removal & Installation Instructions	13
Split Taper Bushing Removal & Installation Instructions	14
Quadwheel [®] Procedure for Cutting a Stump	15
Quadwheel [®] Guarantee	17
Material Safety Data Sheet	18

Disassembly Instructions

1. Remove final drive cover bolts and cover. (Figure 1.1)
2. Remove jackshaft cover bolts and cover. (Figure 1.2)
3. Loosen jackshaft bearing bolts. **Do not remove bolts.** (Figure 1.3)
4. Loosen the front bearing tensioner on the final drive side. (Figure 1.4)
5. Pull the top sheave forward to loosen the final drive belt. (Figure 1.5)



Figure 1.1



Figure 1.2



Figure 1.3



Figure 1.4

Bearing
Tensioner



Figure 1.5

6. Measure from the back final drive cover to the front of the bottom final drive sheave. Record this measurement here as you will need it for reassembly. (Figure 1.6)

Sheave Measurement Notes:



Figure 1.6

7. Remove the bottom final drive sheave. Follow Taper-Lock® bushing removal instructions on page 13. (Figure 1.7)

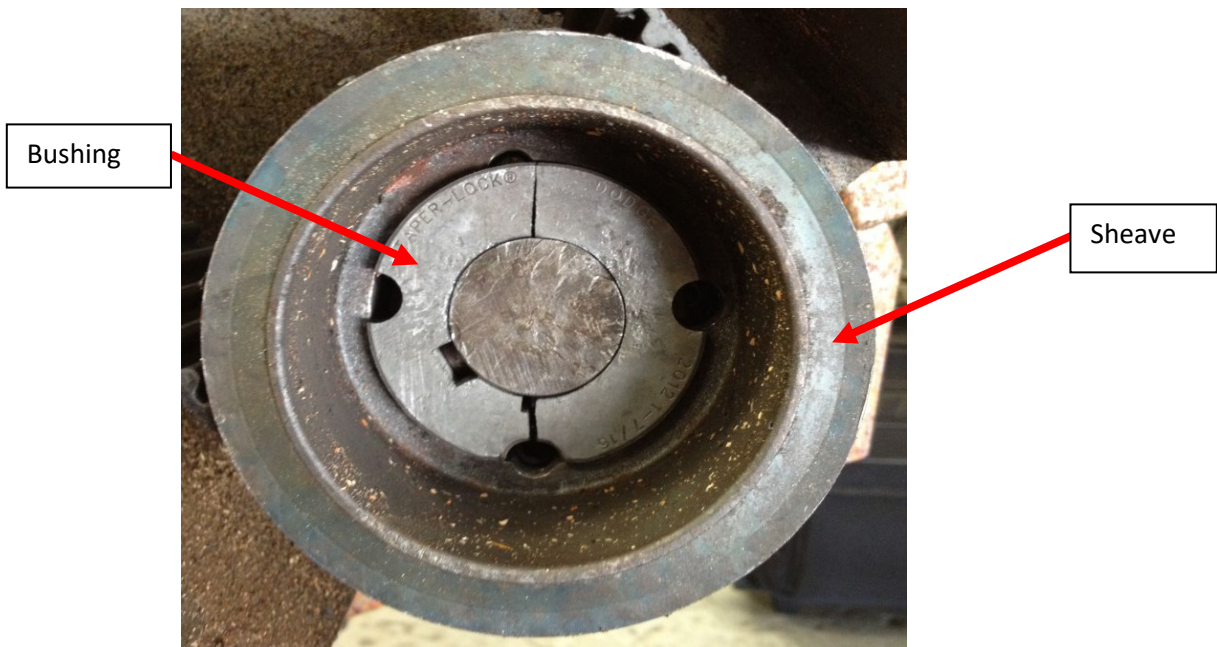

Figure 1.7

- Loosen and remove the left pillow block bearing bolts. (Figure 1.8)



Figure 1.8

- Remove the right pillow block bearing bolts.



Warning: The cutter wheel assembly weighs approximately 112 lbs. Use caution when loosening bolts. The cutter wheel assembly may drop unexpectedly. A floor jack or equivalent lowering device is recommended for easier removal. (Figure 1.8)

- Remove and lower the cutter wheel assembly.

- Loosen two (2) set screws on both the right and left side bearing collars. (Figure 1.9)

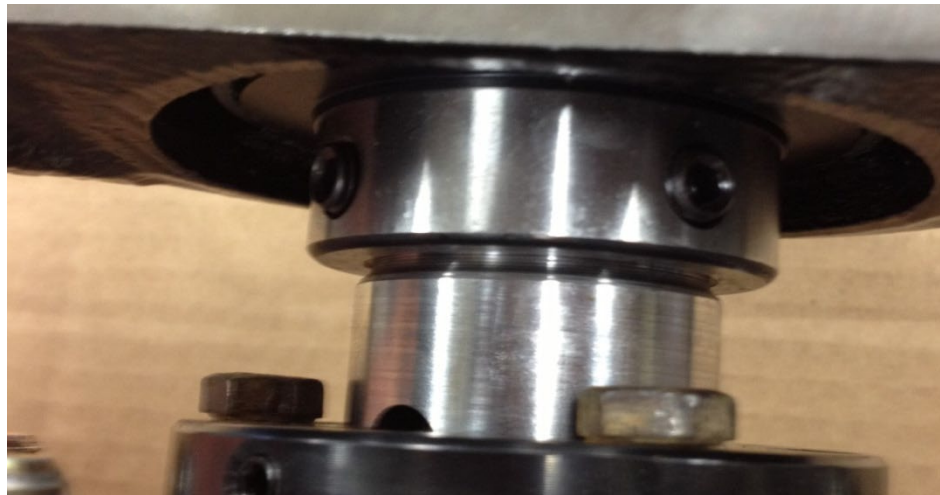

Figure 1.9

- Remove bearings from the cutter wheel shaft. In some instances, bearings may need to be pressed off or cut away from the shaft.

13. Loosen the set screw on the cutter wheel bushing. (Figure 1.10)



Figure 1.10

14. Remove cutter wheel bushing. Follow the split taper bushing removal instructions on page 14.

15. Set shaft, keyway, and cutter wheel bushing off to the side.

16. Remove five (5) nuts and bolts holding the cutter wheel to the wheel hub. Set the hub and bolts off to the side. (Figure 1.11)

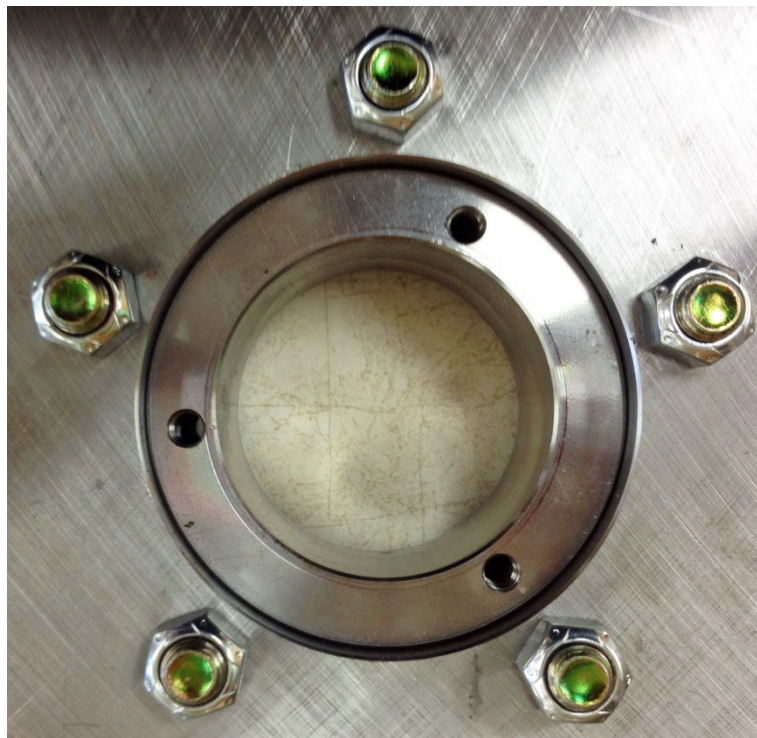

Figure 1.11

Quadwheel® Assembly Instructions

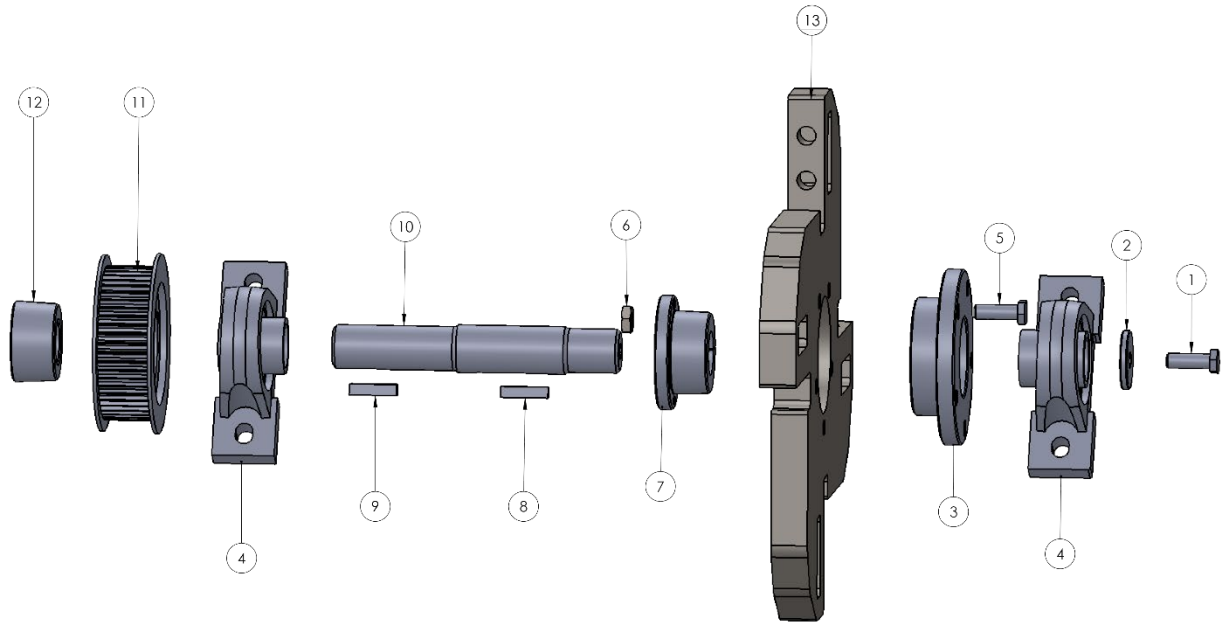

Figure 2.1

(Use Figure 2.1 for the next 8 steps)

1. Mount hub (3) using nuts (6) & bolts (5) to **Quadwheel®** (13).
2. Thread nuts (6) to bolts (5) and torque down firmly.
3. Slide bushing (7) into the hub (3). Thread bushing bolts into the hub loosely. The bushing should have some play on the cutter wheel shaft.
4. Assemble keyway (8) into cutter wheel shaft (10).
5. Slide cutter wheel shaft (10) into bushing (7) aligning keyway (8) with bushing.
6. With the bearing collar facing the **Quadwheel®**, slide the right bearing (4) onto the hub side of the cutter wheel shaft. Tighten two Allen head set screws in the bearing collar
7. Assemble bolt (1) and heavy washer (2) into the hub side of the shaft.
8. With the bearing collar facing the **Quadwheel®**, slide the left bearing onto the opposing side of the cutter wheel shaft. Tighten two Allen head set screws in the bearing collar.

Assembling the *Quadwheel*[®] to Machine

1. With the bolt holes from the bearings lined up with those on the machine, set the cutter wheel in place onto the machine. A floor jack or equivalent lifting device is recommended for easier installation.
2. Loosely reinstall the bearing mounting bolts on the right side of the wheel.
3. Loosely reinstall the bearing mounting bolts on the left side of the wheel.
4. Align & tighten all 4 bearing mounting bolts.
5. With the *Quadwheel*[®] slightly off center to the left, thread cutter wheel bushing bolts $\frac{1}{4}$ of a turn evenly around the bushing. After each rotation of the wheel, check the center position of the wheel to ensure proper centering. (Figure 3.1) Adjust the wheel assembly as needed to maintain proper centering. Tighten the bushing bolts completely as outlined in the split taper bushing installation instructions on page 14.



Figure 3.1

- Loosely install **Quadwheel**® holders and mounting blocks to the wheel. Insert **LoPro**® bolts lubricated with **Green-Seize**™ or equivalent lubricating compound. Torque the wheel holder bolts evenly until you've reached 180 ft. lbs. (240ft. lbs. dry) on each bolt. (Figure 3.2)
- Install **Greenteeth**® on all holder positions and torque to 35 ft. lbs. (Figure 3.2)

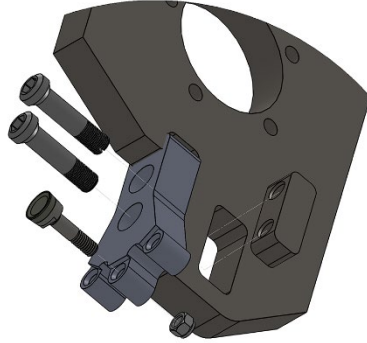

Figure 3.2

- Manually rotate the wheel to ensure each tooth position will have suitable clearance inside the cutter wheel guard. (Figure 3.3)



Figure 3.3

- Place the final drive belt and bottom final drive sheave into the final drive assembly.

10. Reinstall the bottom final drive tapered bushing & sheave to the previously recorded measurement in step 6 of the disassembly instructions. **Follow Taper-Lock® bushing installation instructions on page 13.**
11. Use tensioners to realign jackshaft bearings. Ensure there is proper tension to the final drive belt. Tighten jackshaft bearing nuts once suitable tension to the final drive belt has been achieved.
12. Once the bottom final drive sheave is installed, double-check the measurement from the back final drive cover to the front of both the top and bottom sheaves to ensure even alignment. (Figure 3.4)



Figure 3.4

13. Manually rotate **Quadwheel®** several times and visually ensure the final drive belt maintains a center position to both final drive sheaves. If the final drive belt does not maintain center position on final drive sheaves then adjustments will need to be made. Loosen the bottom final drive bushing and repeat step 10 until the final drive belt maintains a center position on the final drive sheaves.
14. Reinstall the final drive cover.
15. Reinstall the jackshaft cover.
16. Reconnect power to the machine.
17. Start the machine engine and engage the **Quadwheel®**.
18. Ensure there are no unusual noises emanating from the machine.

Quadwheel® Drive Assembly – Expanded View

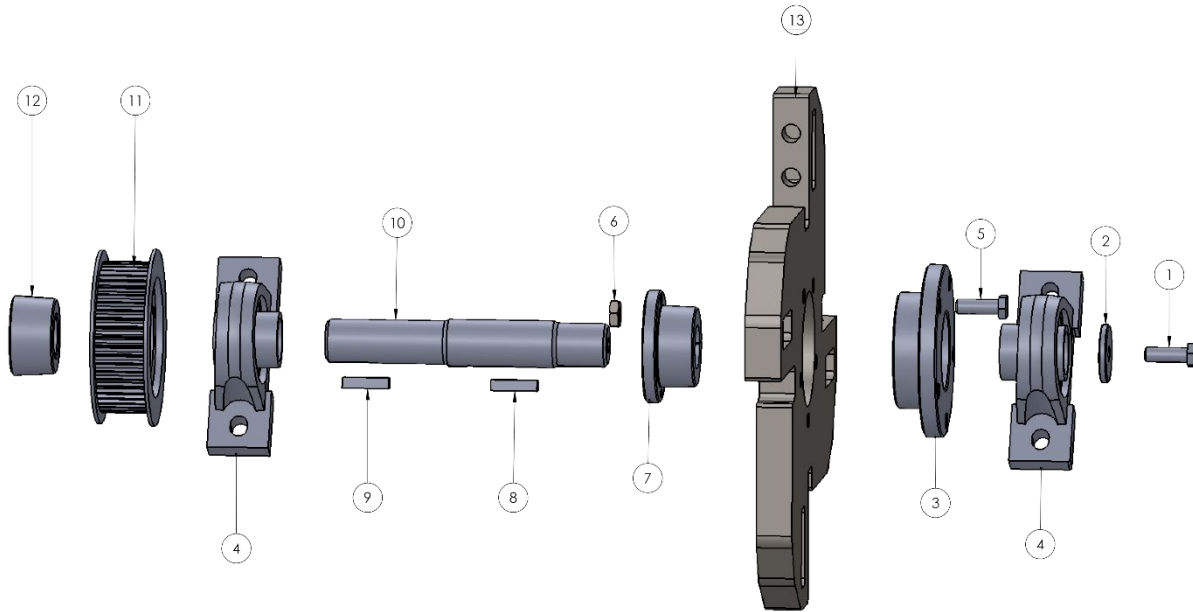

Quadwheel® Drive Assembly			
Item #	Part #	Description	Qty
1		Hex Bolt 1/2 - 13 X 1-1/4	1
2		1/2 Heavy Washer	1
3		Cutter Wheel Hub	1
4		Bearing - PB (1-7/16)	2
5		Hex Bolt 1/2 - 13 X 2-1/2	5
6		Hex Nut 1/2 - 13	5
7		SK 1-1/2 Bushing	1
8		3/8 Bushing Hub Keystock	1
9		3/8 Bushing Sheave Keystock	1
10		Cutter Wheel Shaft	1
11		Sheave	1
12		2012 1-7/16 Taper Lock Bushing	1
13		Quadwheel®	1

Taper-Lock® Bushing Removal & Installation Instructions



Warning: Use of Anti-Seize lubricant on tapered cone surfaces or on bolt threads when mounting may result in damage to sheaves. This voids all manufacturers' warranties.

1. To remove from the shaft:
 - a. Remove all screws.
 - b. Insert screws in holes indicated by ● on the drawing (Figure 4.1). Loosen bushing by alternately tightening screws by following torque specs (Table 1.1).
2. Installation Instructions:
 - a. Clean shaft bore of bushing, outside of bushing, and hub bore of all oil, paint, and dirt. File away burrs.
 - b. Insert bushing into the hub. Match the hole pattern, not threaded holes. Each complete hole will be threaded on one side only.
 - c. Lightly oil set screws and thread into those half-threaded holes indicated by ○ on the drawing (figure 4.1).

CAUTION: Do not lubricate the bushing taper, bushing bore, hub taper, or the shaft. Doing so could result in breakage of the product.
 - d. Position assembly onto the shaft allowing for the small axial movement which will occur during the tightening procedure.
 - e. Alternately torque set screws to the recommended torque setting in the chart below. **CAUTION: Do not use worn hex key wrenches. Doing so may result in a loose assembly or may damage screws.**
 - f. To increase the gripping force, lightly hammer the face of the bushing using a drift or sleeve. Do not hit the bushing directly with a hammer.
 - g. Re-torque screws after hammering.

CAUTION: Where bushing is used with lubricated products such as chain, gear or grid couplings be sure to seal all pathways (where lubrication could leak) with RTV or similar material.
 - h. Recheck screw torques after initial run-in, and periodically thereafter. Repeat steps e, f, and g, if loose.

Insert Screw Torque Table	
Bushing Type	Wrench Torque in./lbs.
2012	192

Table 1.1



○ Insert Screws to Install ● Insert Screws to Remove

Figure 4.1

Split Taper Bushing Removal & Installation Instructions



Warning: Use of Anti-Seize lubricant on tapered cone surfaces or on bolt threads when mounting may result in damage to sheaves. This voids all manufacturer's warranties.

1. To Remove From Shaft:
 - a. Remove the set screw if applicable. Remove cap screws and insert them into tapped holes in the bushing flange. (Figure 5.1)
 - b. Tighten progressively until the bushing disengages.
 - c. Remove assembly from shaft.
2. Installation Instructions:
 - a. Wipe the bushing barrel, bushing bore, and shaft clean with a soft dry cloth. Remove paint & other foreign material from the bore of the mating part. **Do not lubricate the bushing bore of the mating part, shaft, or cap screws.**
 - b. Put bushing loosely into the hub. Start cap screws by hand, turning them just enough to engage threads. Do not use a wrench at this time.
 - c. Slide assembly onto shaft. Line up drive components.
 - d. Tighten cap screws progressively with a torque wrench until each has been tightened to the correct torque. (Table 2.1) Reinstall the set screw if applicable.

Bolt Torque Table		
Bushing Type	Cap Screw Size	Wrench Torque in./lbs.
P	5/16 - 18	192
Q	3/8 - 16	348
SK	5/16 - 18	180
SF	3/8 - 16	360

Table 2.1

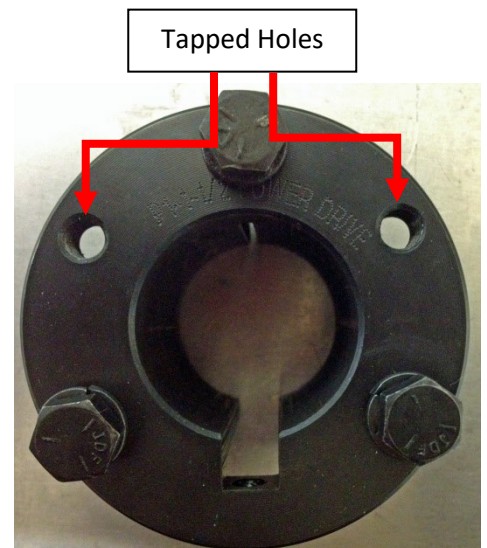

Figure 5.1
(Bushing Only Pictured)

Quadwheel® Procedure for Cutting a Stump



Always follow all warnings and safety guidelines referenced in your equipment manufacturer's manual.

1. Prepare The Machine:
 - a. Drive the machine into position with the cutting wheel shaft above the top front edge of the stump. (Figure 6.1)



Figure 6.1

- b. Engage **Quadwheel®** and move the engine throttle to Fast. (Figure 6.2)

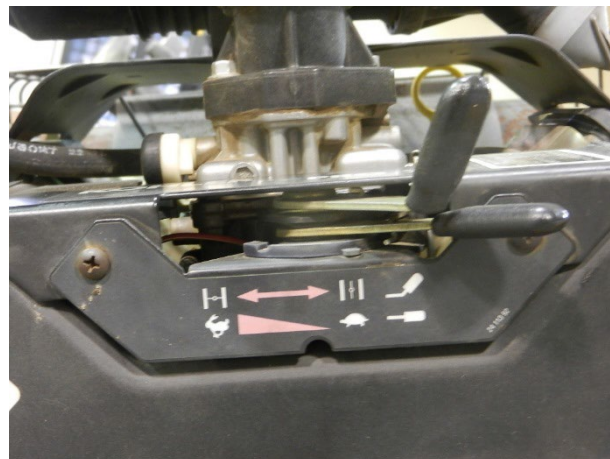

Figure 6.2

- c. While moving the boom left and right, adjust the Left/Right travel to as slow as possible. (Figure 6.3)



Figure 6.3

2. Fine Tune Travel Speed

- a. Lower the **Quadwheel**[®] into the stump. With travel speed set to its lowest setting, swing the cutting wheel across the stump removing as much material as your machine will comfortably cut. Slightly increase the travel speed until the **Quadwheel**[®] is comfortably removing as much material as possible in a single pass. Repeat if necessary. (Figure 6.4)



A depth of cut greater than 1 ½ inches greatly increases the possibility of holder wear and voids all product warranties.



Figure 6.4

QUADWHEEL® GUARANTEE

NEW SETUPS AND FIRST-TIME CUSTOMERS:

If you purchase a **Quadwheel®** setup and are not completely satisfied with its performance, please contact Green Manufacturing at 800.473.3683 to request a return authorization within 90 days of the purchase date for a product refund or exchange.

WARRANTY:

If you are not completely satisfied with your purchase, please contact Green Manufacturing, Inc. at 800.473.3683 to request a return authorization within 30 days of the purchase date for a product refund or exchange. We strive to provide exceptional quality products. Our products undergo a stringent quality control process, however, if you feel that there is an issue with the quality of your product, please contact Green Manufacturing, Inc. immediately. We will accept unused parts for return or exchange for up to 30 days from the date of purchase with proof of purchase included with the return.

Seller's warranties against defects and non-conformities and defects shall continue to apply only so long as the Goods: (i) have been installed, maintained, and used in conformity with instructions furnished by Seller from time to time, if any, and otherwise in conformity with the highest industry practices; (ii) have been subjected to normal use for the purpose for which the Goods were designed; (iii) have not been subjected to misuse, negligence or accident; (iv) have not been altered or repaired by persons other than Seller or Seller authorized warranty service providers in any respect which, in the judgment of Seller, adversely affects the condition or operation of the Goods; and (v) have been fully paid for. IN NO EVENT SHALL SELLER BE LIABLE FOR ANY SPECIAL, INDIRECT, EXEMPLARY, INCIDENTAL, CONSEQUENTIAL, OR PUNITIVE LOSSES OR DAMAGES (INCLUDING, WITHOUT LIMITATION, BUSINESS INTERRUPTION, REVENUE OR PROFITS, FEES OR FINES), EVEN IF SELLER HAS BEEN ADVISED OR MADE AWARE OF THE POSSIBILITY OF ANY SUCH LOSSES OR DAMAGES AND REGARDLESS OF WHETHER THE CLAIM IS BASED ON CONTRACT, TORT, STRICT LIABILITY, OR OTHER THEORY OF LIABILITY. Seller's cumulative liability for all losses and damages under these General Terms and Conditions or under any of the Related Agreements (including, without limitation, those arising out of contract tort (including negligence), strict liability, warranty, or other theory of liability) shall not exceed (a) in the case of any services provided or to be provided by Seller, the amount of the fees payable by Buyer for such services under the applicable Related Agreement, and (b) in the case of any products or devices provided or to be provided by Seller, the amount of Seller's labor services associated with the product sale. Seller reserves the right to make, without notice to Buyer, alterations to a product that do not materially affect agreed specifications or the product's form, fit, or function.

MATERIAL SAFETY DATA SHEET

I - PRODUCT IDENTIFICATION

Trade Name: Tungsten Carbide **Chemical Family:** Refractory Metal Alloy

Chemical Formula: WC **CAS#:** 12070-12-1

II - HAZARDOUS INGREDIENTS

Hazardous Components % OSHA/PEL ACGIH/TLV Sec. 302 Sec. 304 Sec. 313

Tungsten Carbide 0-100 N/E N/E No No No

Tungsten compounds 0-100 5 mg/m³ C - 1 0 mg/m³ No No No

HM IS Ratings (0-4): Health: 3 **Flammability:** 0 **Reactivity:** 0

HM IS Protective Equipment: H: glasses, gloves, clothing, combo respirator

III - PHYSICAL DATA

Boiling Point: 6000 oC **Melting Point:** 2820 - 2940 oC

Evaporation Rate: N/A **% Volatiles:** N/A

Solubility in H₂O: Insoluble **Vapor Pressure:** N/A

Vapor Density: N/E **Specific Gravity:** 13.6 gm/cc at 18 oC

Appearance and Odor: Grey to black powder, odorless **Molecular Weight:** 195.86

IV - FIRE AND EXPLOSION HAZARDS DATA

Flash Point: N/A **Flammability:** Non-Flammable

Explosive Limits: Lower: N/A **Upper:** N/A

Extinguishing Media: Use suitable extinguishing media for surrounding materials and type of fire.

Special Fire Fighting Procedures: Firefighters must wear full face, self-contained breathing apparatus with full protective clothing to prevent contact with skin and eyes. Fumes from fire are hazardous. Isolate runoff to prevent environmental pollution.

Unusual Hazard: Dusts may present a fire or explosion hazard under rare favoring conditions of particle size, dispersion, and strong ignition source. However, this is not expected to be a problem under normal handling conditions.

V - HEALTH HAZARD INFORMATION

Routes of Entry: Inhalation, ingestion, skin or eye contact (for dusts, mists, powder, and fume).

Effects of Overexposure: Industrially tungsten does not constitute an important health hazard. Exposure is related chiefly to the dust arising out of the crushing and milling operations. Chronic inhalation of the dust may cause lung damage in humans. Heavy exposure to the dust or the large amounts of the soluble compounds produces changes in body weight, behavior, blood cells, choline esterase activity and sperm in experimental animals.

Acute Effects:

Inhalation: Toxic by inhalation. May cause irritation to the mucous membranes, coughing, dyspnea, soreness in the chest, weight loss, hemoptysis, bronchitis, asthma, pulmonary fibrosis and radiological changes in the lungs.

Ingestion: May cause irritation to the gastrointestinal tract and diarrhea.

Skin: May cause irritation.

Eye: May cause irritation.

Chronic Effects:

Inhalation: May cause damage to the lungs.

Ingestion: No chronic health effects recorded.

Skin: May cause dermatitis, sensitization and eczema.

Eye: May cause conjunctivitis.

Medical Conditions Generally Aggravated by Exposure: Pre-existing respiratory and skin disorders.

Target Organs: May affect the respiratory system.

Carcinogenicity: NTP: No IARC: No OSHA: No

EMERGENCY AND FIRST AID PROCEDURES:

INHALATION: Remove victim to fresh air. Keep warm and quiet, give oxygen if breathing is difficult and seek medical attention.

INGESTION: If conscious, give 1-2 glasses of milk or water and induce vomiting (Never induce vomiting or give anything by mouth to an unconscious person). Seek medical attention.

SKIN: Remove contaminated clothing from affected area, brush material off skin. Wash affected area with mild soap and water. Seek medical attention if symptoms persist.

EYE: Flush eyes with lukewarm water, lifting upper and lower eyelids, for at least 15 minutes. Seek medical attention if symptoms persist.

VI - REACTIVITY DATA

Stability: Stable

Conditions to Avoid: None

Incompatibility (Material to Avoid): Chlorine, fluorine, nitrogen dioxide, nitrous oxide, iodine pentafluoride and lead oxide.

Hazardous Decomposition Products: None recorded.

Hazardous Polymerization: Will not occur.

VII - SPILL OR LEAK PROCEDURES

Steps to Be Taken in Case Material Is Released or Spilled: Wear appropriate respiratory and protective equipment specified in Section VIII. Isolate spill area and provide ventilation. Vacuum up spill using a high efficiency particulate absolute (HEPA) air filter and place in a closed container for proper disposal. Take care not to raise dust.

Waste Disposal Method: Dispose of in accordance with all local, state, and federal regulations.

VIII - SPECIAL PROTECTION INFORMATION

Respiratory Protection: NIOSH approved dust, mist, and vapor cartridge respirator.

Ventilation: Use local exhaust ventilation which is adequate to limit personal exposure to airborne dust levels which do not exceed the appropriate PEL or TLV. If such equipment is not available, use respiratory protection as specified above.

Protective Gloves: Rubber gloves.

Eye Protection: Safety glasses.

Other Protective Clothing or Equipment: Protective gear suitable to prevent contamination.

IX - SPECIAL PRECAUTIONS

Precautions to Be Taken in Handling and Storage: Store in a tightly sealed container in a cool, dry, well-ventilated area. Wash thoroughly after handling.

Other Precautions: Implement engineering and work practice controls to reduce and maintain concentration of exposure at low levels. Use good housekeeping and sanitation practices. Do not use tobacco or food in work area. Wash thoroughly before eating or smoking. Do not blow dust off clothing or skin with compressed air.

The above information is believed to be correct, but does not purport to be all inclusive and shall be used only as a guide. Green Manufacturing, Inc. shall not be held liable for any damage resulting from handling or from contact with the above product.

The Quadwheel® is proudly manufactured in the USA by Green Manufacturing, Inc.

Green Manufacturing, Inc.
9650 Packard Rd
Morenci, MI 49256
Phone 800.473.3683 • Fax 517.458.1550

