

Vermeer 352 & 372 *Quadwheel*[®] Installation & Operation Guide



If you have any questions or concerns, *please call 1-800-473-3683*



BEFORE YOU BEGIN

Read these instructions completely and carefully

- **Note to installer** – Be sure to leave these instructions for the consumer's use
- **Note to consumer** – Keep these instructions with your Owner's Manual for future reference
- **Skill level** – Installation of the wheel requires intermediate mechanical skills. Proper installation is the responsibility of the installer. Product failure due to improper installation is not covered under any warranty
- **Helpful tips** – When installing a new v-belt it is recommended to check belt tension after 1 hour, 5 hours, 10 hours and 25 hours of machine operation as the belt will stretch.

IMPORTANT - Before you continue, please check the packing list to make sure it matches the contents of the boxes.



Disconnect Power

to machine to prevent any machine components from moving before proceeding. Failure to do so could result in death or serious injury.

FOR YOUR SAFETY read and observe all **CAUTIONS** and **WARNINGS** shown throughout these instructions. While performing the installations that are described in this booklet, gloves & safety glasses or goggles should be worn at all times.

Installation Preparation

TOOLS SUPPLIED:

½" Drive, ½" 6pt Impact Allen Wrench Socket

TOOLS YOU WILL NEED:

5/8" Socket Wrench

½" Drive Torque Wrench

Green-Seize™

TORQUE SETTINGS:

900 Series Nut: 35ft. lbs. (47Nm)

LoPro® Bolt (lubricated with **Green-Seize™**): 180 to 200ft. lbs. (244 Nm)

MANUFACTURER'S PARTS LIST:

Part Number	Description
926-WS2	900 Series Wearsharp® 2-sided Tooth, for wheels 22" & smaller, Used with Greenwheel® & Quadwheel®
GW-BLOCK	Greenwheel® Mounting Block
GW-HOLDER	Greenwheel® Holder
LP-300	3" LoPro® Bolt
ALLENWRENCH-SOCKET	½" Drive, ½" 6pt Impact Allen Wrench Socket

Green Manufacturing, Inc.
9650 Packard Rd
Morenci, MI 49256
Phone 800.473.3683 • Fax 517.458.1550



Table of Contents

Disassembly Instructions	4
Assembling the Quadwheel [®] to Machine	5
Quadwheel [®] Drive Assembly - Expanded View	7
Quadwheel [®] Procedure for Cutting a Stump	8
Quadwheel [®] Guarantee	10
Material Safety Data Sheet	12

Disassembly Instructions

 **Warning:** The cutter wheel assembly weighs approximately 112 lbs. Use caution when loosening bolts. Cutter wheel assembly may drop unexpectedly. Floor jack or equivalent lowering device is recommended for easier removal.

1. Remove 6 bolts attaching center cover and wheel to the cutter wheel hub. (Figure 1.1)

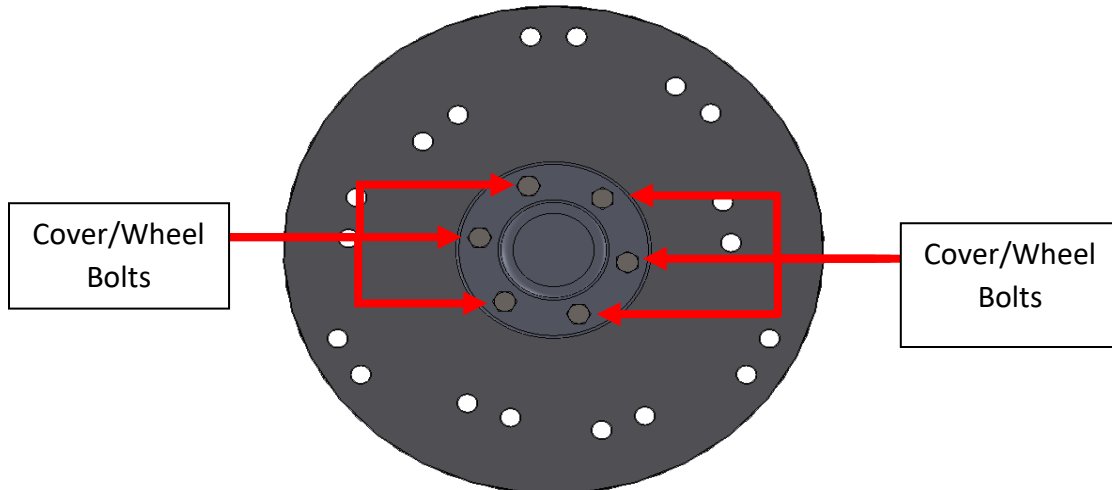

Figure 1.1

1. Remove center cover
2. Remove cutter wheel.

Assembling the **Quadwheel**[®] to Machine

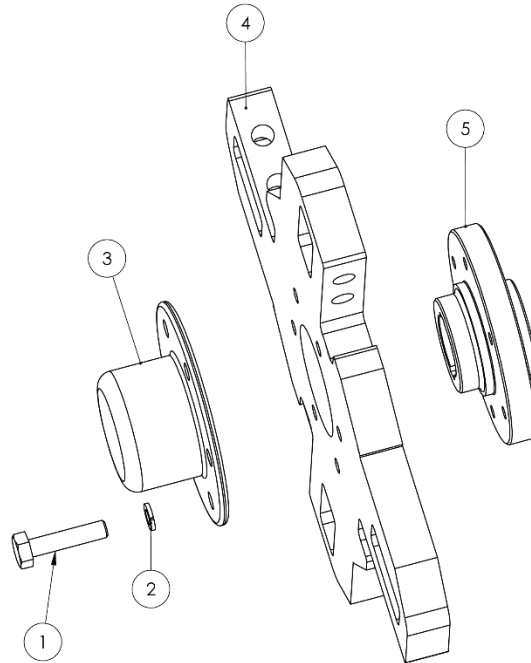

Figure 2.1

(Use Figure 2.1 for the next 4 steps)

1. Install the **Quadwheel**[®] (4) to the cutter wheel hub (5).
2. Align bolt holes of cutter wheel hub (5) and the **Quadwheel**[®] (4).
3. Align center wheel cover (3) bolt holes to the **Quadwheel**[®] (4).
4. Reinstall 6 cutter wheel bolts (1) and lock washers (2) torquing to 93ft. lbs. (120Nm).
5. Loosely install **Quadwheel**[®] holders and mounting blocks to the wheel. Insert **LoPro**[®] bolts lubricated with **Green-Seize**[™] or equivalent lubricating compound. Torque the wheel holder bolts evenly until you've reached 180 ft. lbs. (244Nm) on each bolt. (Figure 2.2)

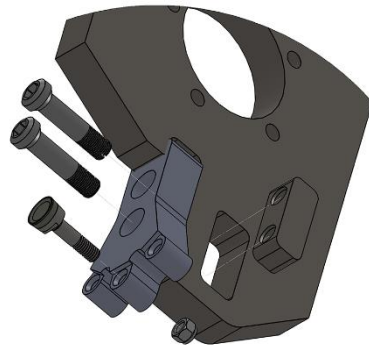
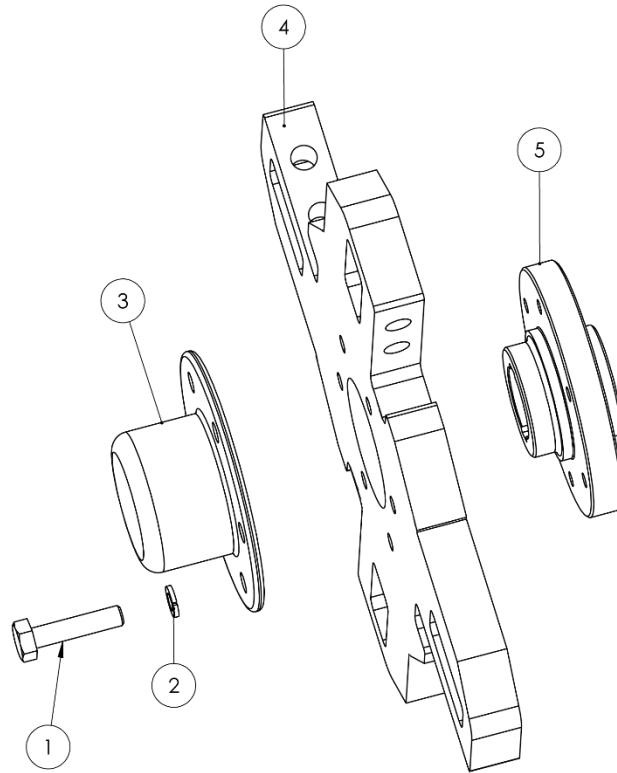

Figure 2.2

6. Install **Greenteeth**[®] on all holder positions and torque to 35 ft. lbs. (47Nm) (Figure 2.2)

7. Manually rotate the wheel to ensure each tooth position will have suitable clearance inside cutter wheel guard.
8. Reconnect power to machine.
9. Start machine engine and engage the ***Quadwheel***[®].
10. Ensure that there are no unusual noises emanating from the machine.

Quadwheel® Drive Assembly – Expanded View



Quadwheel® Drive Assembly			
Item #	Part #	Description	Qty
1		M12 – 1.75 x 60 Hex Head Bolt	6
2		M12 Plain Steel Lock Washer	6
3		Center Wheel Cover	1
4		Quadwheel®	1
5		Cutter Wheel Hub	1

Quadwheel® Procedure for Cutting a Stump



Always follow all warnings and safety guidelines referenced in your equipment manufacturer's manual.

1. Prepare The Machine:

- a. Drive the machine into position with the cutting wheel shaft above the top front edge of the stump. (Figure 3.1)

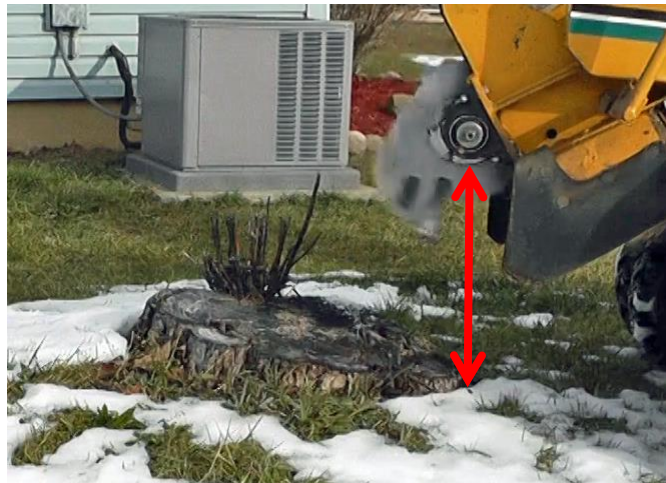

Figure 3.1

- b. Engage **Quadwheel®** and move the engine throttle to Fast. (Figure 3.2)

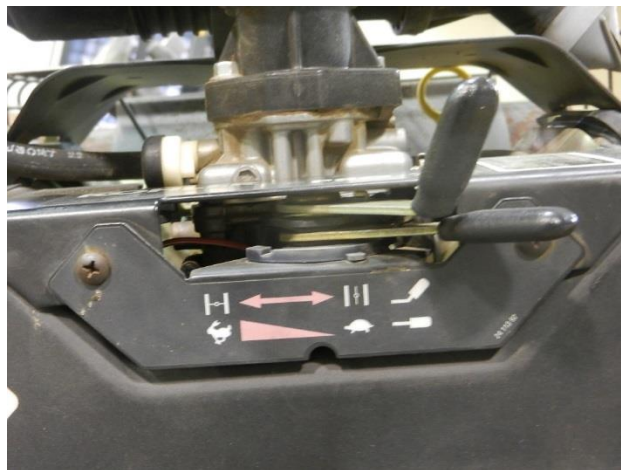

Figure 3.2

- c. While moving the boom left and right, adjust the Left/Right travel to as slow as possible. (Figure 3.3)



Figure 3.3

2. Fine Tune Travel Speed
3. Lower the **Quadwheel**[®] into the stump. With travel speed set to its lowest setting, swing the cutting wheel across the stump removing as much material as your machine will comfortably cut. Slightly increase the travel speed until the **Quadwheel**[®] is comfortably removing as much material as possible in a single pass. Repeat if necessary (**A depth of cut greater than 1 ½ inches greatly increases the possibility of holder wear and voids all product warranties**). (Figure 3.4)



Figure 3.4

QUADWHEEL® GUARANTEE

NEW SETUPS AND FIRST TIME CUSTOMERS:

If you purchase a **Quadwheel™** setup and are not completely satisfied with its performance, please contact Green Manufacturing at 800.473.3683 to request a return authorization within 90 days of purchase date for a product refund or exchange.

WARRANTY:

If you are not completely satisfied with your purchase, please contact Green Manufacturing, Inc. at 800.473.3683 to request a return authorization within 30 days of purchase date for a product refund or exchange. We strive to provide exceptional quality products. Our products undergo a stringent quality control process, however if you feel that there is an issue with the quality of your product, please contact Green Manufacturing, Inc. immediately. We will accept unused parts for return or exchange for up to 30 days from the date of purchase with proof of purchase included with the return.

Seller's warranties against defects and non-conformities and defects shall continue to apply only so long as the Goods: (i) have been installed, maintained and used in conformity with instructions furnished by Seller from time to time, if any, and otherwise in conformity with the highest industry practices; (ii) have been subjected to normal use for the purpose for which the Goods were designed; (iii) have not been subjected to misuse, negligence or accident; (iv) have not been altered or repaired by persons other than Seller or Seller authorized warranty service providers in any respect which, in the judgment of Seller, adversely affects the condition or operation of the Goods; and (v) have been fully paid for. IN NO EVENT SHALL SELLER BE LIABLE FOR ANY SPECIAL, INDIRECT, EXEMPLARY, INCIDENTAL, CONSEQUENTIAL, OR PUNITIVE LOSSES OR DAMAGES (INCLUDING, WITHOUT LIMITATION, BUSINESS INTERRUPTION, REVENUE OR PROFITS, FEES OR FINES), EVEN IF SELLER HAS BEEN ADVISED OR MADE AWARE OF THE POSSIBILITY OF ANY SUCH LOSSES OR DAMAGES AND REGARDLESS OF WHETHER THE CLAIM IS BASED ON CONTRACT, TORT, STRICT LIABILITY, OR OTHER THEORY OF LIABILITY. Seller's cumulative liability for all losses and damages under these General Terms and Conditions or under any of the Related Agreements (including, without limitation, those arising out of contract tort (including negligence), strict liability, warranty, or other theory of liability) shall not exceed (a) in the case of any services provided or to be provided by Seller, the amount of the fees payable by Buyer for such services under the applicable Related Agreement, and (b) in the case of any products or devices provided or to be provided by Seller, the amount of Seller's labor services associated with the product sale. Seller reserves the right to make, without notice to Buyer, alterations to a product that do not materially affect agreed specifications or the product's form, fit or function.

The Quadwheel® is proudly manufactured in the USA by Green Manufacturing, Inc.

Green Manufacturing, Inc.
9650 Packard Rd
Morenci, MI 49256
Phone 800.473.3683 • Fax 517.458.1550



MATERIAL SAFETY DATA SHEET

I - PRODUCT IDENTIFICATION

Trade Name: Tungsten Carbide **Chemical Family:** Refractory Metal Alloy

Chemical Formula: WC **CAS#:** 12070-12-1

II - HAZARDOUS INGREDIENTS

Hazardous Components % OSHA/PEL ACGIH/TLV Sec. 302 Sec. 304 Sec. 313

Tungsten Carbide 0-100 N/E N/E No No No

Tungsten compounds 0-100 5 mg/m³ C - 1 0 mg/m³ No No No

HM IS Ratings (0-4): Health: 3 **Flammability:** 0 **Reactivity:** 0

HM IS Protective Equipment: H: glasses, gloves, clothing, combo respirator

III - PHYSICAL DATA

Boiling Point: 6000 oC **Melting Point:** 2820 - 2940 oC

Evaporation Rate: N/A % **Volatiles:** N/A

Solubility in H₂O: Insoluble **Vapor Pressure:** N/A

Vapor Density: N/E **Specific Gravity:** 13.6 gm/cc at 18 oC

Appearance and Odor: Grey to black powder, odorless **Molecular Weight:** 195.86

IV - FIRE AND EXPLOSION HAZARDS DATA

Flash Point: N/A **Flammability:** Non-Flammable

Explosive Limits: Lower: N/A **Upper:** N/A

Extinguishing Media: Use suitable extinguishing media for surrounding materials and type of fire.

Special Fire Fighting Procedures: Firefighters must wear full face, self-contained breathing apparatus with full protective clothing to prevent contact with skin and eyes. Fumes from fire are hazardous. Isolate runoff to prevent environmental pollution.

Unusual Hazard: Dusts may present a fire or explosion hazard under rare favoring conditions of particle size, dispersion, and strong ignition source. However, this is not expected to be a problem under normal handling conditions.

V - HEALTH HAZARD INFORMATION

Routes of Entry: Inhalation, ingestion, skin or eye contact (for dusts, mists, powder, and fume).

Effects of Overexposure: Industrially tungsten does not constitute an important health hazard. Exposure is related chiefly to the dust arising out of the crushing and milling operations. Chronic inhalation of the dust may cause lung damage in humans. Heavy exposure to the dust or the large amounts of the soluble compounds produces changes in body weight, behavior, blood cells, choline esterase activity and sperm in experimental animals.

Acute Effects:

Inhalation: Toxic by inhalation. May cause irritation to the mucous membranes, coughing, dyspnea, soreness in the chest, weight loss, hemoptysis, bronchitis, asthma, pulmonary fibrosis and radiological changes in the lungs.

Ingestion: May cause irritation to the gastrointestinal tract and diarrhea.

Skin: May cause irritation.

Eye: May cause irritation.

Chronic Effects:

Inhalation: May cause damage to the lungs.

Ingestion: No chronic health effects recorded.

Skin: May cause dermatitis, sensitization and eczema.

Eye: May cause conjunctivitis.

Medical Conditions Generally Aggravated by Exposure: Pre-existing respiratory and skin disorders.

Target Organs: May affect the respiratory system.

Carcinogenicity: NTP: No IARC: No OSHA: No

EMERGENCY AND FIRST AID PROCEDURES:

INHALATION: Remove victim to fresh air. Keep warm and quiet, give oxygen if breathing is difficult and seek medical attention.

INGESTION: If conscious, give 1-2 glasses of milk or water and induce vomiting (Never induce vomiting or give anything by mouth to an unconscious person). Seek medical attention.

SKIN: Remove contaminated clothing from affected area, brush material off skin. Wash affected area with mild soap and water. Seek medical attention if symptoms persist.

EYE: Flush eyes with lukewarm water, lifting upper and lower eyelids, for at least 15 minutes. Seek medical attention if symptoms persist.

VI - REACTIVITY DATA

Stability: Stable

Conditions to Avoid: None

Incompatibility (Material to Avoid): Chlorine, fluorine, nitrogen dioxide, nitrous oxide, iodine pentafluoride and lead oxide.

Hazardous Decomposition Products: None recorded.

Hazardous Polymerization: Will not occur

VII - SPILL OR LEAK PROCEDURES

Steps to Be Taken in Case Material Is Released or Spilled: Wear appropriate respiratory and protective equipment specified in Section VIII. Isolate spill area and provide ventilation. Vacuum up spill using a high efficiency particulate absolute (HEPA) air filter and place in a closed container for proper disposal. Take care not to raise dust.

Waste Disposal Method: Dispose of in accordance with all local, state, and federal regulations.

VIII - SPECIAL PROTECTION INFORMATION

Respiratory Protection: NIOSH approved dust, mist, and vapor cartridge respirator.

Ventilation: Use local exhaust ventilation which is adequate to limit personal exposure to airborne dust levels which do not exceed the appropriate PEL or TLV. If such equipment is not available, use respiratory protection as specified above.

Protective Gloves: Rubber gloves.

Eye Protection: Safety glasses.

Other Protective Clothing or Equipment: Protective gear suitable to prevent contamination.

IX - SPECIAL PRECAUTIONS

Precautions to Be Taken in Handling and Storage: Store in a tightly sealed container in a cool, dry, well-ventilated area. Wash thoroughly after handling.

Other Precautions: Implement engineering and work practice controls to reduce and maintain concentration of exposure at low levels. Use good housekeeping and sanitation practices. Do not use tobacco or food in work area. Wash thoroughly before eating or smoking. Do not blow dust off clothing or skin with compressed air.

The above information is believed to be correct, but does not purport to be all inclusive and shall be used only as a guide. Green Manufacturing, Inc. shall not be held liable for any damage resulting from handling or from contact with the above product.